

rotoweld 3.0

Maintenance Manual

Automated welding
work cell for
pipe spool
prefabrication

tecnar

Innovate to differentiate.

1 FLEXIBLE CABLE CARRIER MAINTENANCE	6
1.1 How to replace damaged covers and broken links	6
2. TRACK SYSTEM MAINTENANCE.....	9
2.1 Chain for motorization maintenance.....	9
3. WELDING CARRIAGE MAINTENANCE.....	10
3.1 Water cooler maintenance	10
3.1.1 Routine maintenance	10
3.1.2 Reservoir coolant level.....	10
3.1.3 Clean or replace the pump inlet strainer	10
3.1.4 Pump motor	12
3.1.5 Heat exchanger	12
3.2 Gas flow meter maintenance	13
3.3 Wire feeder maintenance	14
3.4 Pressurized flux feed tank maintenance	15
3.5 STT arc sensor maintenance	18
3.6 Pyrometer maintenance.....	19
3.7 Foot pedal maintenance.....	19
3.7.1 Main & Secondary positioner:	19
3.7.2 Carriage:.....	20
3.8 Carriage wheels maintenance	20
3.9 Motorization sprocket maintenance	22
3.10 Welding manipulator maintenance	23
3.10.1 X Y position torch reference	24
3.10.2 Servo Control timing belt.....	24
3.11 Root & Fill torch maintenance.....	28
3.11.1 Nozzle, contact tip, gas diffuser & liner replacement.....	28
3.11.2 How to replace QUICK LOAD™ liners into retainer pin	29
3.11.3 How to replace conventional liners	30
3.12 SAW fill torch maintenance.....	31
3.13 Control station Maintenance.....	32
3.13.1 Monitor and computer enclosure maintenance	32
3.13.2 Fan filters maintenance	38
4 POSITIONERS MAINTENANCE.....	39
4.1 Rotative ground maintenance.....	39
4.2 Gas cylinder pressure regulator maintenance.....	40
4.3 Self centering chuck maintenance	41
4.4 Gears assembly maintenance	41
4.4.1 Gear lubrication.....	42

4.4.2 Gear box maintenance	42
4.4.3 Gear backlash maintenance.....	43
4.6 Pillow blocks maintenance	43
4.7 Root power source maintenance.....	45
4.7.1 STT II Preventive maintenance.....	45
4.7.2 STT II input filter capacitor discharge procedure.....	46
4.7.3 STT module Power wave S500 Preventive maintenance	47
4.8 Fill power source maintenance.....	48

5 PIPE STANDS 49

5.1 Hydraulic cylinder, hoses connection maintenance	50
5.2 Locking hydraulic valve maintenance	50
5.3 Wheels maintenance	50
5.4 Flux pan maintenance	50

6 MAINTENANCE SCHEDULE RECOMMENDED 51

6.1 Daily.....	51
6.2 Weekly	51
6.3 Monthly	52
6.4 Quarterly.....	52
6.5 Annually	53

Other Rotoweld documentation:

Rotoweld **Startup Manual** (40101-00059); requirements, step by step and startup electrical installation.

Rotoweld **Cold Installation Manual** (40101-00032); requirements and step by step mechanical installation.

Rotoweld **User interface** (40101-00033); detailed information of all the menus and sub menus.

Rotoweld **Operation Manual** (40101-00034); detailed information on how to weld with the system.

Rotoweld **Troubleshooting Manual** (40101-00035); in case of hardware issues.

Rotoweld **Welding Manual** (40101-00036); welding program creation plus welding tips using the Rotoweld.

Rotoweld **Technical Description Manual** (40101-00037); hardware description.

Rotoweld **Prodatalog Manual** (40101-00056); viewer for all the welding data history logged.

Rotoweld **Maintenance schedule** (40101-00058).

Rotoweld **Suggested Welding Parameters** (40103-00252 TO 40103-00257); baseline parameters for welding programs.

This system is easy to maintain and will deliver many years of operations. We are proposing the actions required in time in a table at the end of the document. To begin, components location will be showed with description explanations related with maintenance. Furthermore, detailed actions required to perform on each of the sub components. Should questions arise, feel free to contact us at service@tecnar.com

1 FLEXIBLE CABLE CARRIER MAINTENANCE

This is important to keep the base clean where the cable carrier is moving to avoid early abrasion of the plastic links, also visual inspection for broken covers or links to be replaced.

The articulated cable carrier is a flexible conduit that contains the electrical cables, gas lines and connectors required between the welding carriage and the main positioner.

1.1 How to replace damaged covers and broken links



1. To raise the lids of the Cable track management system, insert a flat screwdriver in the appropriate hole (see picture) and pull down at each extremity of the lid.



2. Pull down at each extremity of the lid



3. For removing a section raise at least 3 lids and remove two of them.

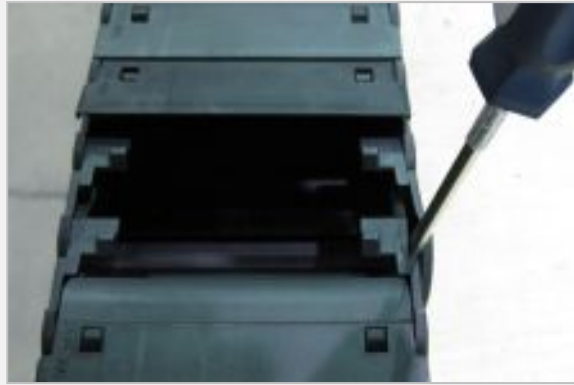

4. Insert flat screwdriver in the side panel between the two sections and push carefully to the outside and pull out the two sections from each other.

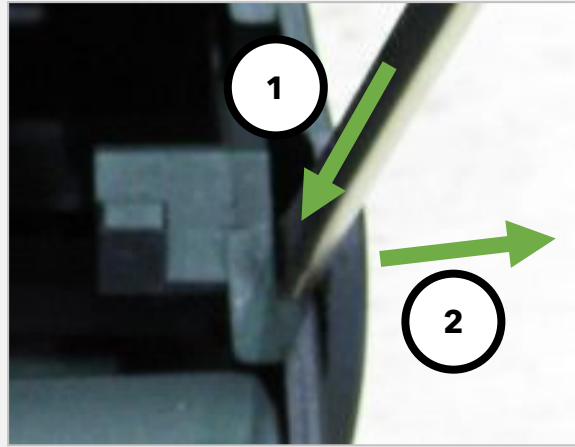

5. Push carefully to the outside



6. Pull out the two sections from each other.



7. For the installation of the flange, raise 3 lids and remove 2 of them.



8. To insert the flange in the chain, insert one side at the time. Make sure the sections are correctly inserted.



Regular lids



Flange lids

Note:

We have included with the Nylatube 12 regular and 2 flange spare lids. You have two different lids. The one without the little ears is the one for the flange and the other one is for the regular chain.

2. TRACK SYSTEM MAINTENANCE

Keep the surface of the track system clean, use a broom, compress air or vacuum. This assure the welding carriage and pipe stands can move along the tracks smoothly.

2.1 Chain for motorization maintenance

Validation of the chain tension, we put the carriage at a certain distance of the end of the track and we determine an amount play we suggest.

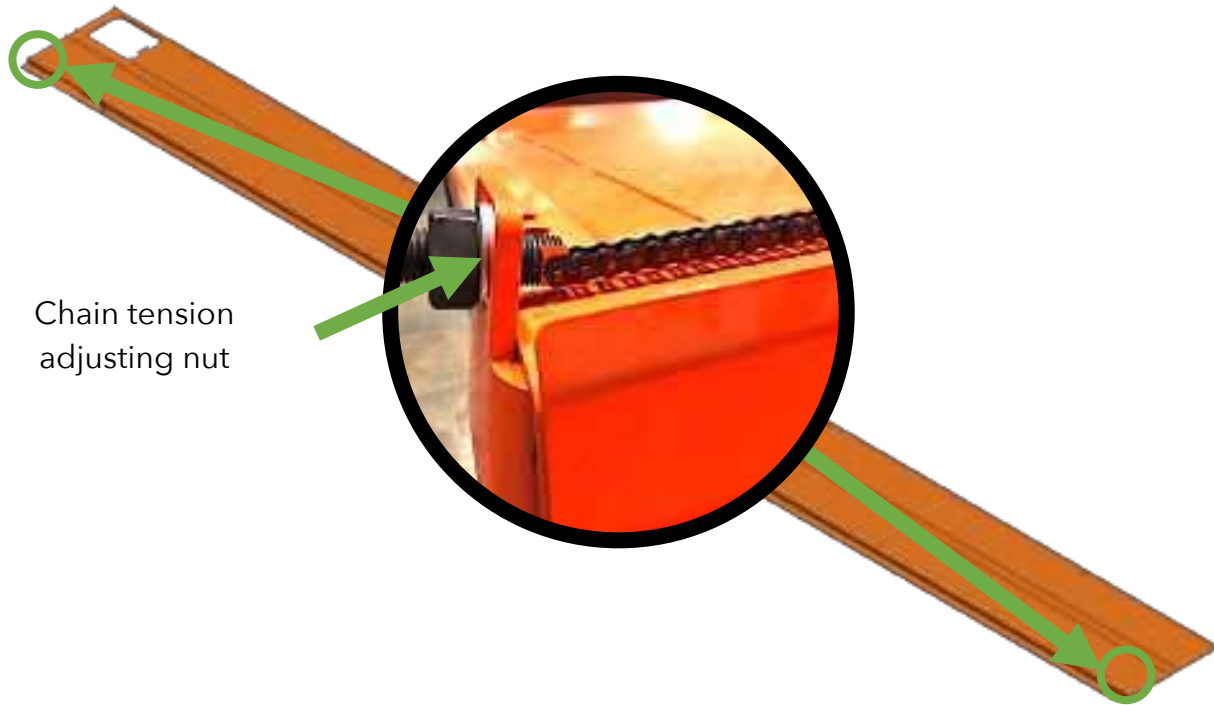

Chain tension
adjusting nut

Chain tensioner localization

3. WELDING CARRIAGE MAINTENANCE

3.1 Water cooler maintenance

3.1.1 Routine maintenance

1. Remove accumulated dust and dirt from the internal components of the cooler by blowing it out with a low-pressure air hose or removing the dust and dirt with a vacuum hose.



Validate if the fans are operating

Fan location



3.1.2 Reservoir coolant level

The reservoir volume should be checked monthly.

1. Remove the reservoir fill cap and check the coolant level. The reservoir is full when the coolant level is just below the reservoir fill opening. Keep the reservoir full, especially after disconnecting the water lines or changing the accessory being cooled.

3.1.3 Clean or replace the pump inlet strainer



Warning

The pump head has a "built in" strainer on the inlet side of the pump. It is recommended to clean or replace the pump inlet strainer at least once a year.

1. Drain coolant from the reservoir and open the case of the water cooler. Located the pump.



2. Hold pump head to apply counter-torque when loosening strainer's 7/8 acorn nut. Do not confuse with 3/4 acorn nut. Remove nut and slide inlet strainer down and out from pump head.



3. Inspect strainer for damage or excessive clogging: Replace or gently rinse the strainer under running water to thoroughly clean it.
4. Use a mirror to inspect the inside of the pump for contamination. If hardened debris is present and interferes with filter seating, carefully remove it with a dental pick without scratching inside of the pump. Use care not to drop debris into the pump.
5. Reinstall strainer and acorn nut, tightening with 75 ± 15 in.-lbs. of torque.
6. Hold pump head to apply counter-torque when loosening strainers 7/8 acorn nut.
7. Add 2 gallons of coolant constituted of 1 gallon (4 liters) of water and 1 gallon (4 liters) of glycol.

3.1.4 Pump motor

The COOL ARC® 40 is rated for continuous operation.

It is recommended to re-oil the pump motor bearings once a year as follows:

1. Remove the plastic plugs located on the top of both the inboard and outboard bearing endcaps.



2. Re-oil each bearing with 30-35 drops of SAE 20 oil then reinstall both plugs.

3.1.5 Heat exchanger

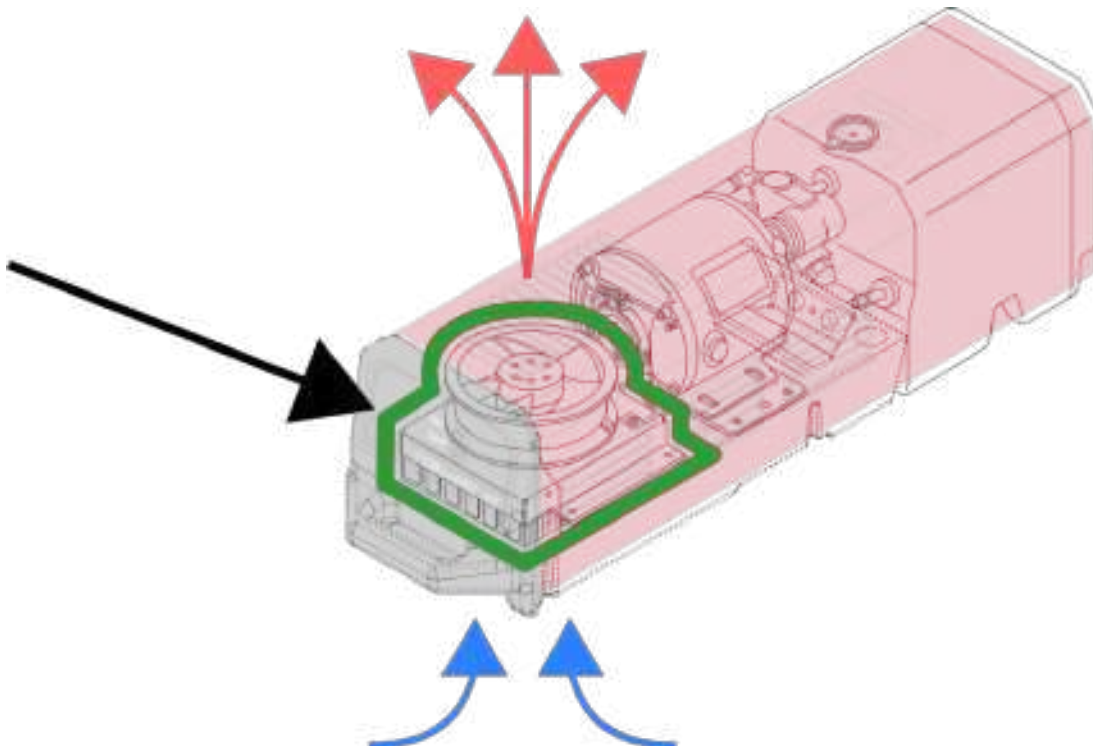

To maintain maximum cooler efficiency, the heat exchanger should be kept free of dust and dirt buildup.

1. Clean the heat exchanger periodically using a vacuum hose or a low-pressure compressed air line. Avoid placing the unit near a flux hopper or a flux waste container. A clean heat exchanger offers better cooling performance and longer product life. In extremely dirty environments, it may be necessary to remove the heat exchanger completely from the cooler and clean the fins with soap and water. Use care to avoid damaging the fins.

3.2 Gas flow meter maintenance

1. Verify for leaks at the flow meter connections with soap & water.





2. Verify for leaks at the shielding gas cylinder input connections at the pressure regulators with soap & water.

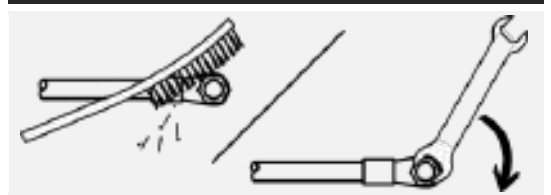
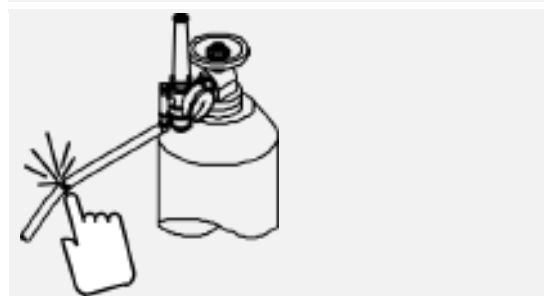
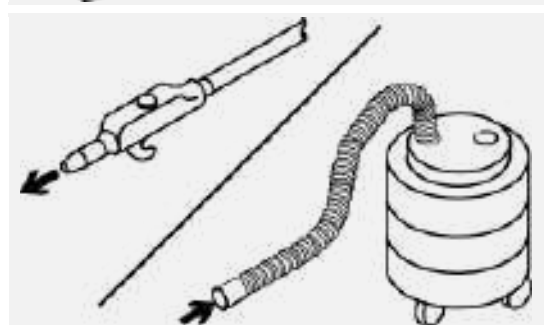
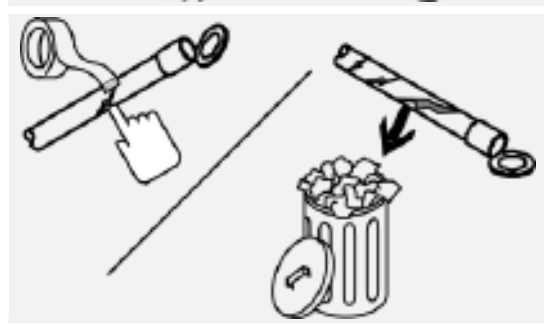

3.3 Wire feeder maintenance

 Disconnect main power before maintenance

Section	Maintenance
	1. Clean and tighten wire feeder weld terminals.
	2. Repair or replace cracked weld cable
	3. Blow out or vacuum inside.
	4. Repair or replace cracked weld cable
	5. Clean drive roll

3.4 Pressurized flux feed tank maintenance

- ▽ Shut down the air pressure valve before attempting any services

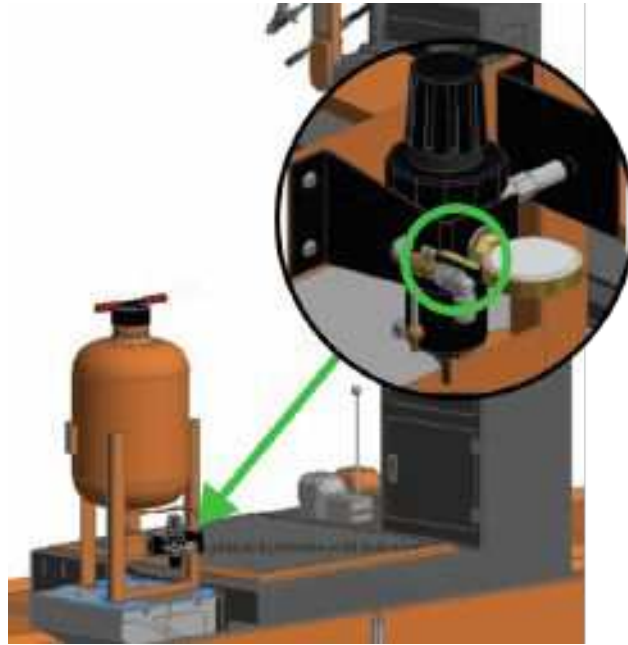

Localization



Maintenance

1. Carefully unscrew the cover of the flux tank. Do not unscrew completely. Allow the remaining air to escape completely from the reservoir. When the air is completely removed from the reservoir you can unscrew the cap completely.



2. Do services if needed



3. Install the tank cover and make sure it is properly tightened so that air does not escape.

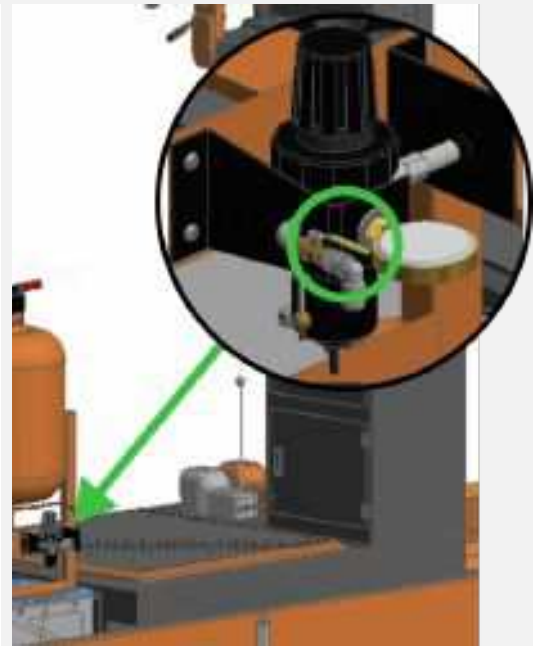

4. Open the air valve

3.5 STT arc sensor maintenance

1. Verify the wire, clamp and magnet for damages, repair or replace if required.



3.6 Pyrometer maintenance

1. Verify the wire, clean the sensor input reader.
2. Point the carriage with the pyrometer, the temperature reading should be close to the ambient temperature. If not, service is required. Refer to the manual of the pyrometer.

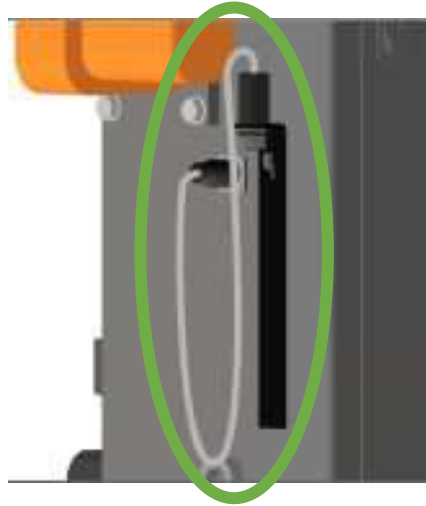

3.7 Foot pedal maintenance

3.7.1 Main & Secondary positioner:

1. Test the foot pedal functionality, forward reverse and the estop.
2. Visual inspection of the electrical cables for damages.
3. Repair or replace damaged wiring.



3.7.2 Carriage:

1. Test the foot pedal functionality, forward reverse.
2. Visual inspection of the electrical cables for damages.
3. Repair or replace damaged wiring.

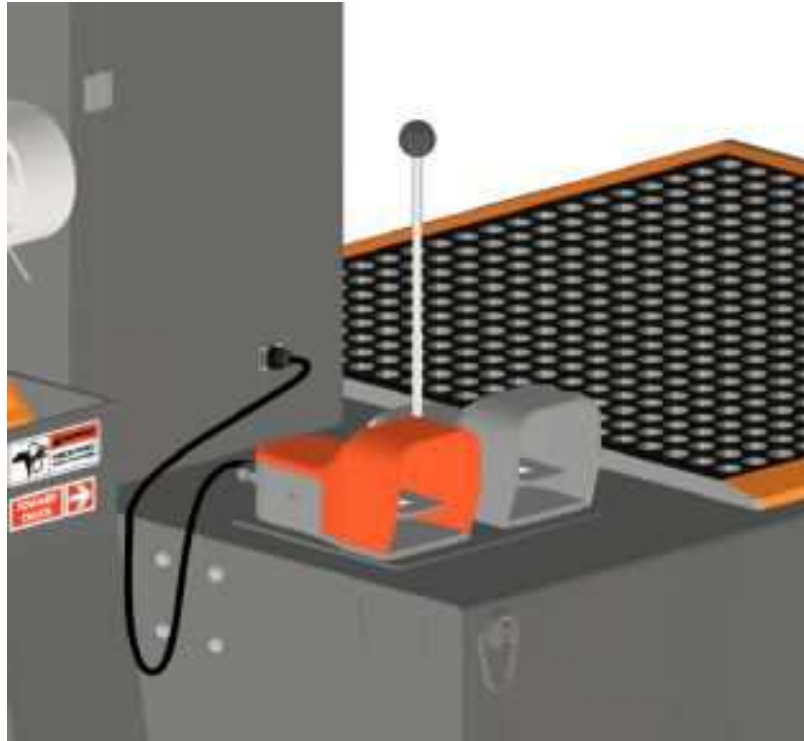

3.8 Carriage wheels maintenance

Lubrification of the wheel.

1. Use the zerk grease fitting to lubricate each wheel.

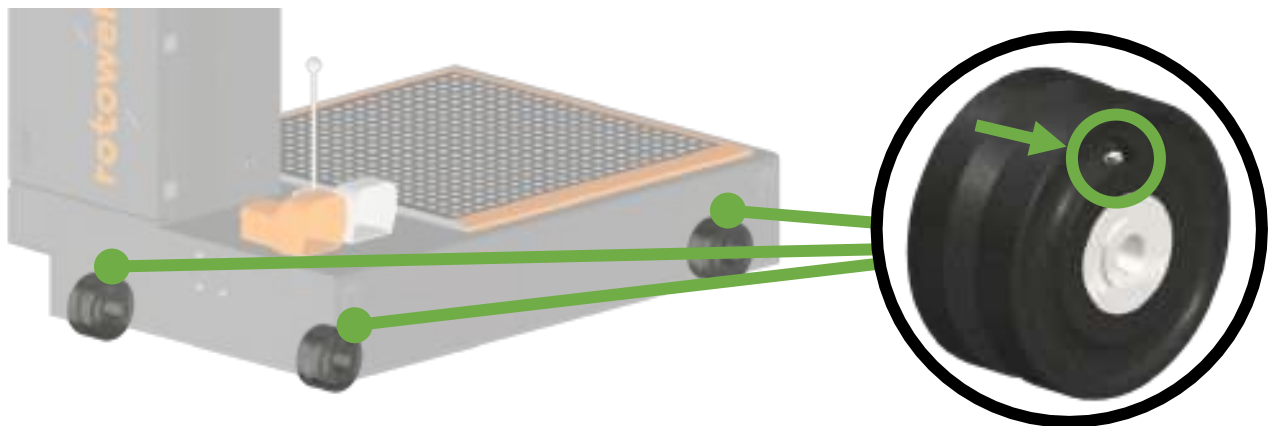



Use Valvoline Crimson or equivalent multipurpose grease



VALVOLINE™ CRIMSON™ GREASE

Valvoline Crimson Grease is a preference among users with multiple grease applications, operating at moderate load carrying capacities, pressure, and temperature ranges. It is formulated with tackiness to heighten its ability to adhere to metal surfaces, and mobility for ease of pumping. This grease is fortified with an additive package that provides anti-wear protection, EP, rust and oxidation inhibition and copper corrosion resistance. Applications include: Trucking, Industrial, Agriculture and Automotive.

Typical Properties:	ASTM Method	NLGI #2
Thickener		Lithium
Color	Visual	Red
KV@40 (cSt)	D445	ISO 220
Density		7.46 lb/gal
Operating Temp Range, °F		25-250
Timken, lbs.	D2509	45
4-ball wear, scar diameter, mm	D2266	<0.6 max
4-Ball EP Load Wear Index @ XX kg	D2596	250
Load Wear Index	D2596	45
Rust Prevention	D1743	Pass
Dropping point, °F	D2265	380
Mobility @ 60°F	US Steel	350 min

Part Numbers:	NLGI #2
Bulk	VV70118
Tote	VV70117
400 Lb. Drum	VV70119
120 Lb. Keg (L)	VV70120
35 Lb. Plastic Pail	VV70122
50/14 Oz. Carton	VV70124

Refer to Valvoline's Safety Data Sheet for health and safety information.

This information only applies to products manufactured in the following location(s): USA, Canada.

3.9 Motorization sprocket maintenance

1. Validation the sprocket is tight on the transmission shaft axis and the height of the sprocket in the chain is properly set.

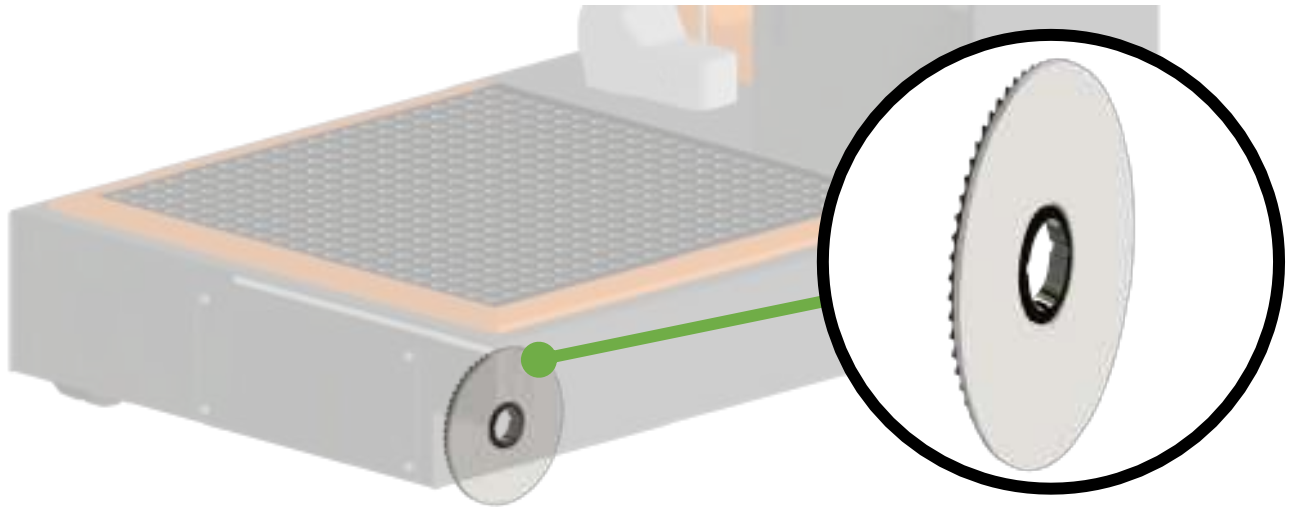

3.10 Welding manipulator maintenance

Two welding torches are connected to the manipulator. One torch is used for the root pass, and the other is used for the fill passes.

Two welding torch kits are available:

- MIG/MIG
- MIG/SAW

Depending on the option you purchased, for the MIG/MIG version, there will be only this set of torches. If the SAW option is chosen, you will have both kits of torches MIG/MIG and MIG/SAW so you can swap depending on the welding processes you want to use. Each torch kit contains the liners, gas line, contact tips, gas nozzle, gas diffuser and cooling line that are appropriate for the intended welding process.



MIG/MIG



MIG/SAW



The MIG/SAW kits come with specific features for SAW welding:

- Specific tip and nozzle.

- Flux feeding hose (red in the right picture).

- Specific frame on top of the carriage to guide the MIG/SAW torch assembly, which is heavier than the MIG/MIG assembly.

3.10.1 X Y position torch reference

Proper location of the X & Y welding tool point is important to maintain the required welding torches positions on the pipe. To proceed to welding arm calibration please contact Tecnar service team at service@tecnar.com

3.10.2 Servo Control timing belt

Timing belt for J1, J2, and J3 motorization.

1. Verify if the belts are not slack. If the belt is loose, open the appropriated section and tight the belt.

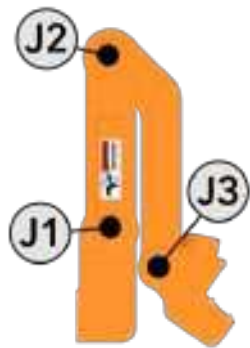

Motor drive localization

J1:

2. Unscrew the 4 screws of the motor without removing them.

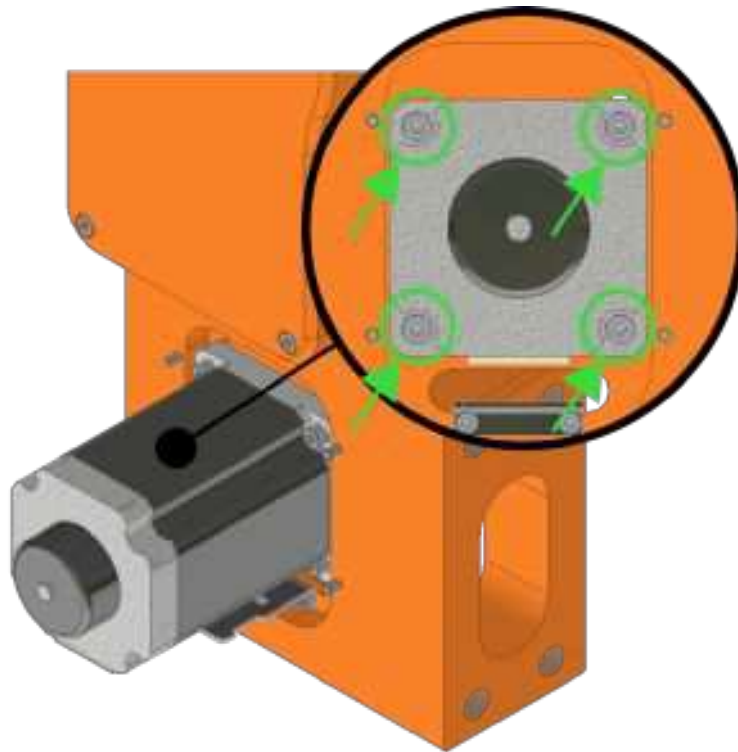

3. Adjust the timing belt tension. When the desire tension is reached, tight the 4 screws previously mentioned in step 1.

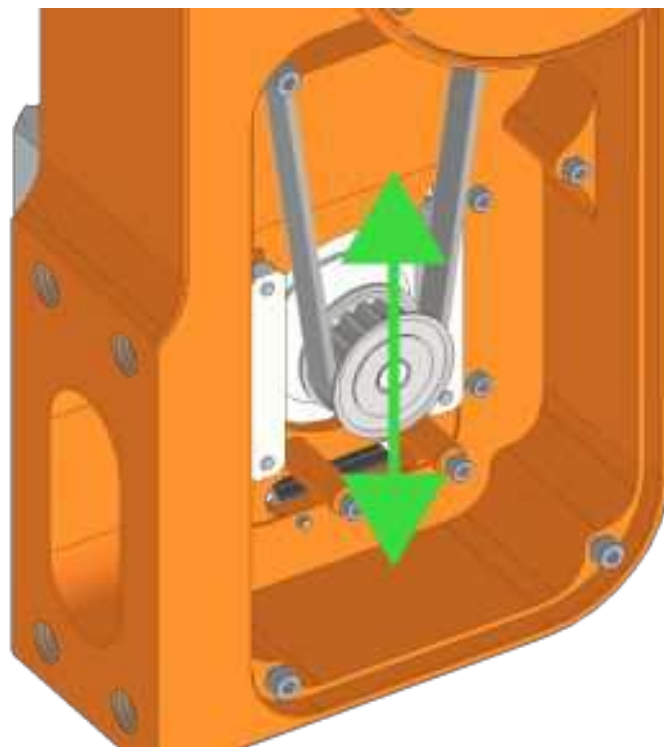

J2:

4. Unscrew the 4 screws of the motor without removing them.

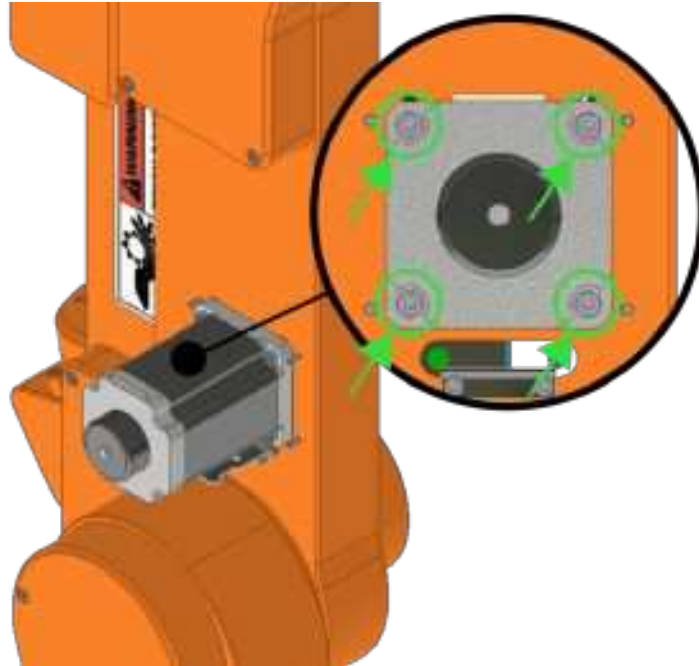

5. Adjust the timing belt tension. When the desire tension is reached, tight the 4 screws previously mentioned in step 1.



J3:

6. Unscrew the 4 screws of the motor without removing them.

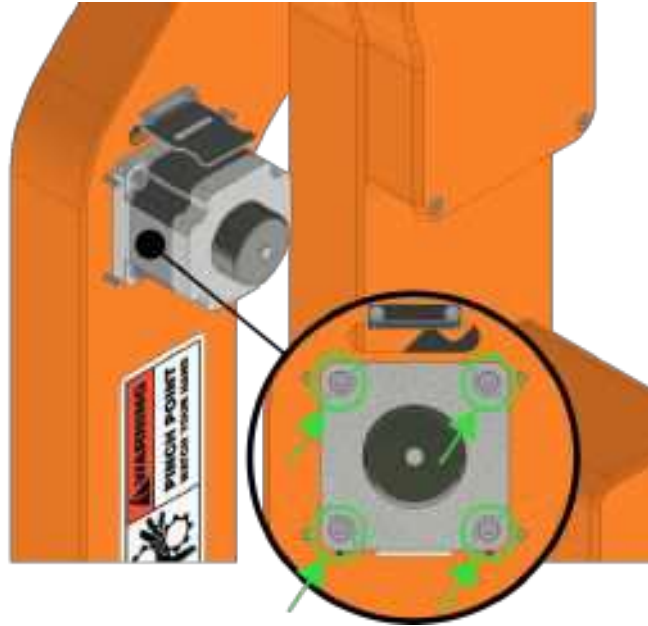

7. Adjust the timing belt tension. When the desire tension is reached, tight the 4 screws previously mentioned in step 1.

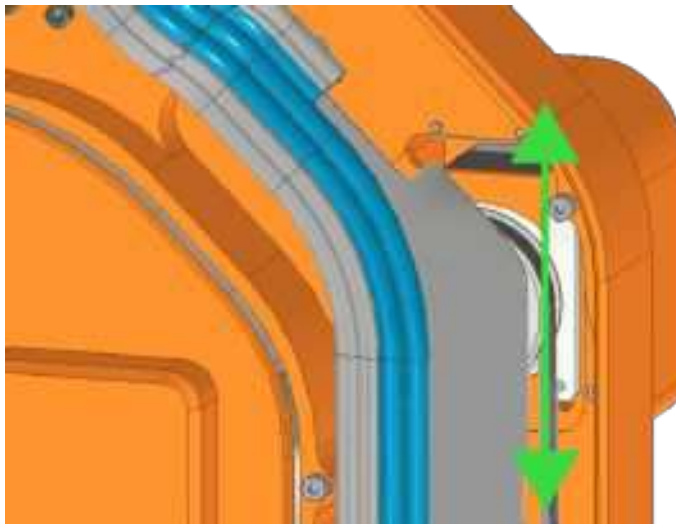

3.11 Root & Fill torch maintenance

3.11.1 Nozzle, contact tip, gas diffuser & liner replacement

1. Clean or replace nozzle if necessary.



2. Clean or replace tip if necessary.



3. Clean or replace gas diffuser if necessary.



3.11.2 How to replace QUICK LOAD™ liners into retainer pin



Retainer pin

Install the liner from the back of the MIG gun with the retainer attached using the same procedure as a conventional liner.



1. Remove consumables (nozzle, contact tip and retaining head).



2. Pull the existing QUICK LOAD Liner from the neck using pliers.
3. Remove the protective cap from the new QUICK LOAD Liner.



4. Insert the QUICK LOAD Liner through the neck using the wire as a guide. Push the QUICK LOAD Liner in using short strokes to prevent the wire from kinking.



WITH RETAINER:

5. Once the QUICK LOAD Liner stops feeding, give it an extra push to ensure it bottoms out and is inserted completely.

T with a 3/4" (20 mm) stick out (BLACK Liner Gauge provided).

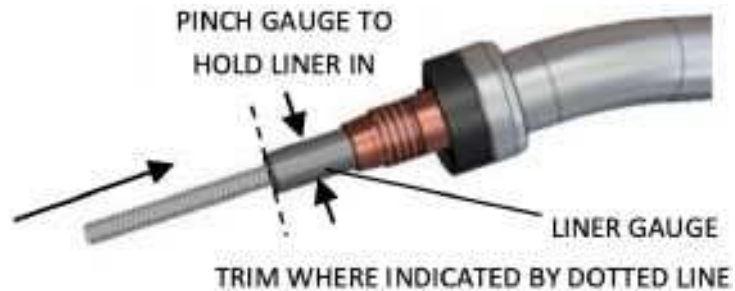

6. Reinstall consumables.

3.11.3 How to replace conventional liners

1. Remove consumables (nozzle, contact tip and gas diffuser).



2. Remove power pin using a 10mm wrench, turn tread-in liner collet counter-clockwise until liner is free from the power pin

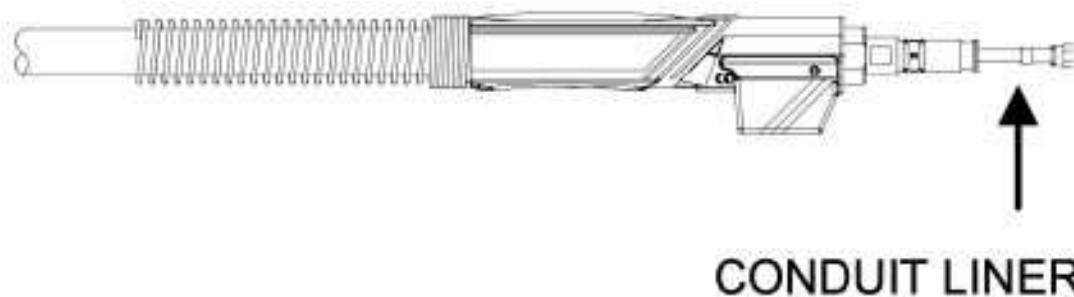

3. Grip conduit liner with plier and remove
4. Feed the replacement liner through the gun using short strokes to avoid kinking. Twist the liner clockwise if necessary.
5. Using a 10mm wrench, turn thread-in liner collet in a clockwise direction and tighten in the power pin.

6. Push the liner back into the gun and hold in place.
7. Using the Liner Gauge, trim the conduit liner with a 3/4" (20 mm) stick out.

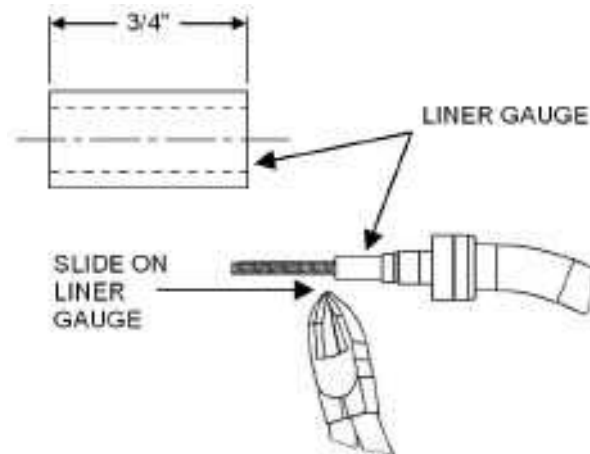

8. Reinstall consumables.

3.12 SAW fill torch maintenance

Use the same method for liner change as mention above.

In case of malfunction of the flux valve clean the inside filter and/or inspect the rubber pinch valve for hole or tear.

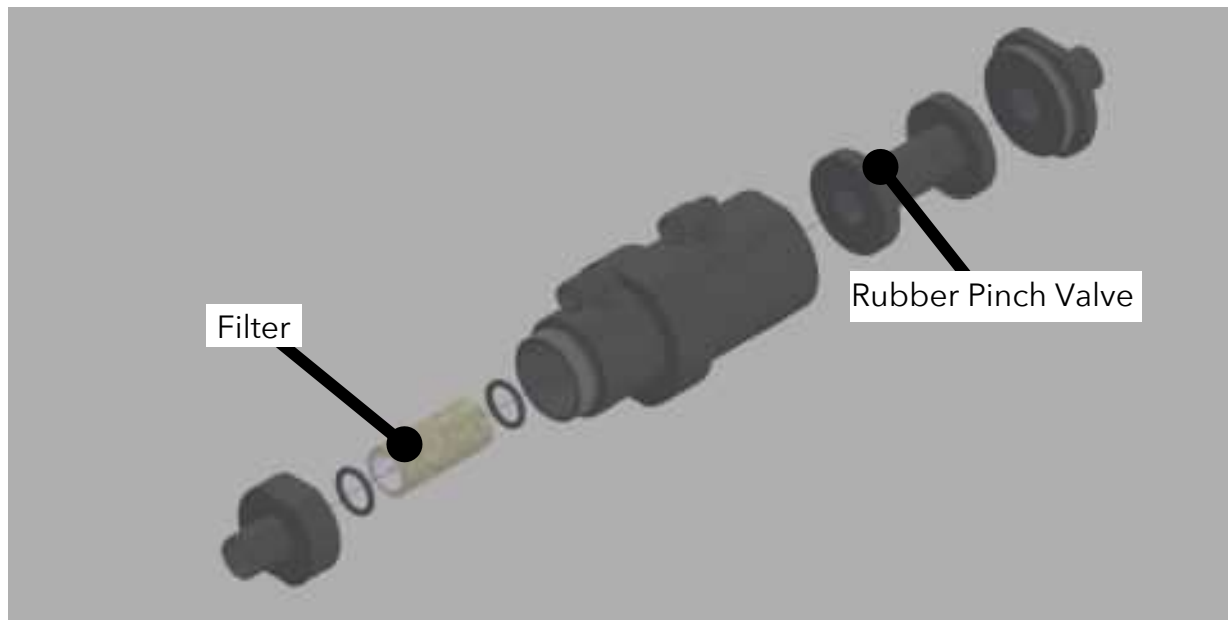

3.13 Control station Maintenance

3.13.1 Monitor and computer enclosure maintenance

How to clean the monitor protective

1. Shut down the Rotoweld system
2. Turn the Power Key to the off position.



3. Turn the Torch button to Up and hold to the right until the arm is completely calibrate. The Rotoweld will shut down.

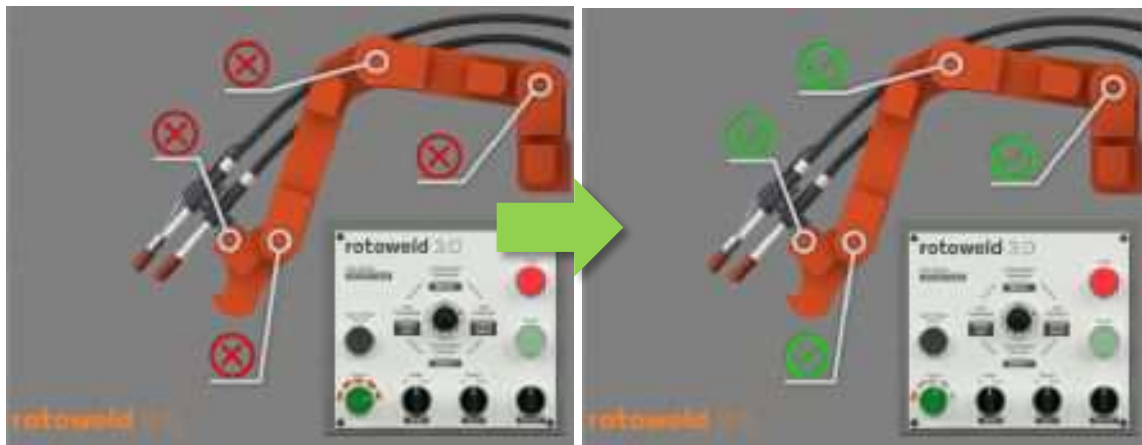

4. Once the computer shut down process is completed, wait 1 minute.

⚠ Never switch the main power off before steps 1 and 2 are completed.

5. Turn off the main power switch.



The monitor cabinet is located on the carriage where the main software is displayed.

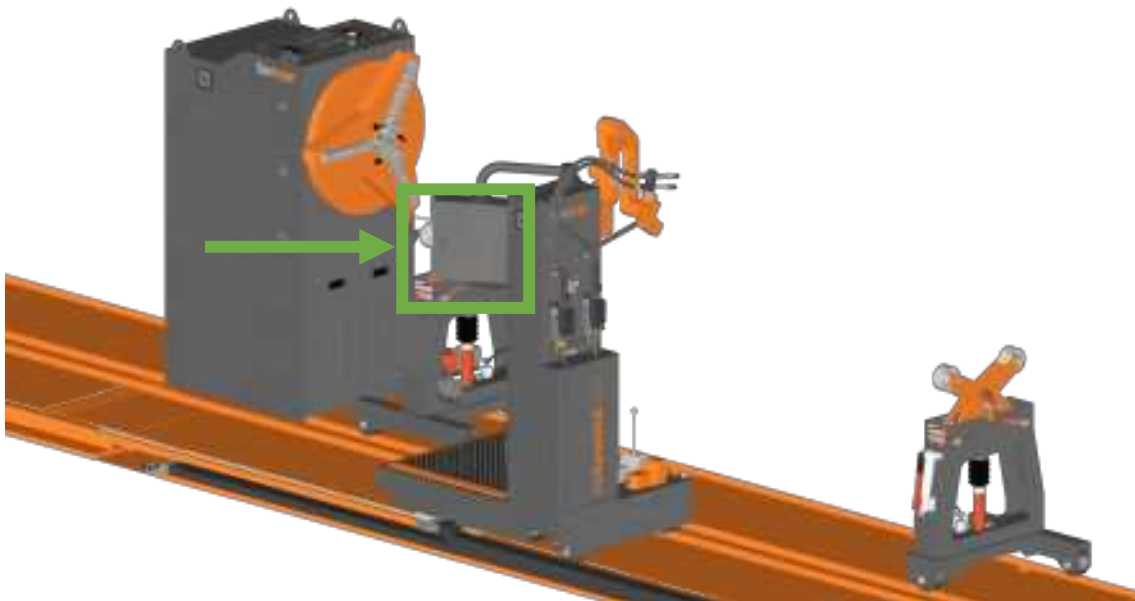

6. Open the back panel of the monitor cabinet to access the monitor.



7. Loosen the 4 screws of the bracket mount of the computer without unscrewing them completely.
8. Once the screws are loosened enough, lift the computer, and tilt the bottom portion slightly so that it disengages from the bottom bracket.
9. Pull down to release the top bracket from the bottom bracket.



10. Unplug all wires linked to the monitor. Voltage and video cable.



▽ Pull down the sleeve of the power connector before pulling down the cable of the outlet voltage.



Locked position - Don't pull out



Unlocked position - Pull out

11. Remove the 4 screws that hold the monitor to the cabinet housing and then remove the monitor.

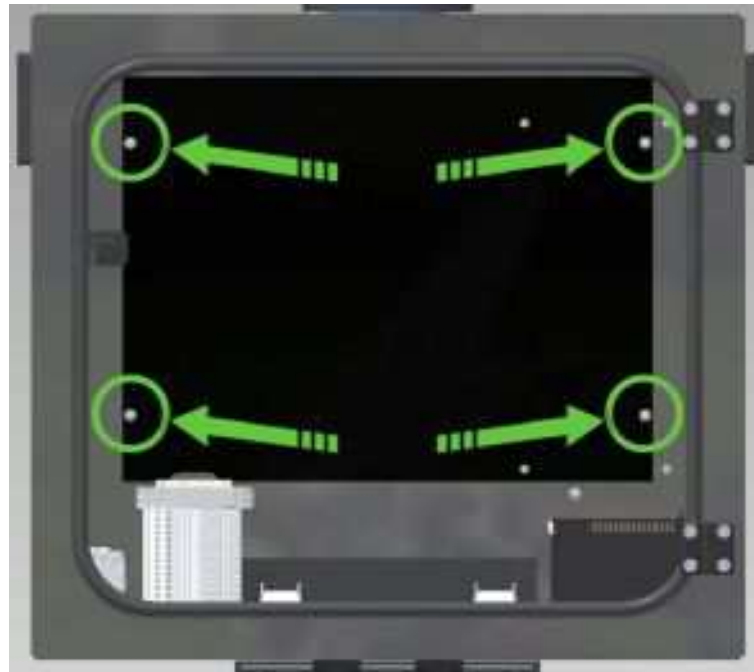

12. Clean the plexiglass window with light soap and gently wipe dust on the monitor screen with a dry clean rag.
13. Remove dust from the complete inside of the monitor cabinet with compressed air (Make sure that there is no Oil or water expelled from the compressed air hose) or vacuum.

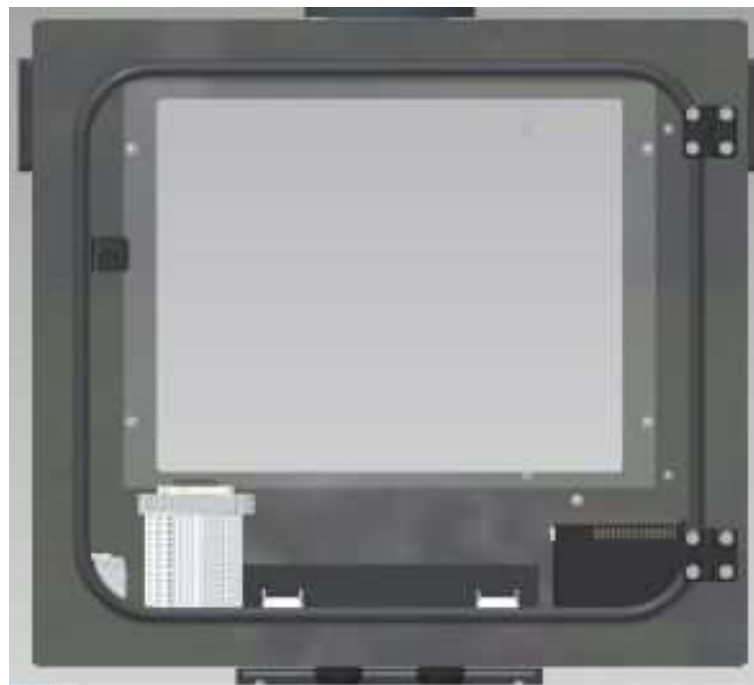

Reinstalling the monitor and the computer

Reassemble the monitor inside of the cabinet housing.

1. Install the 4 screws that hold the monitor. Connect the 12vdc power cable and the video cable to the monitor.



2. Reinstall the computer to its initial location and tighten all 4 screws.



3. Close the back panel of the cabinet.

3.13.2 Fan filters maintenance

1. Clean or change filter accordingly



Fan monitor right



Fan monitor left

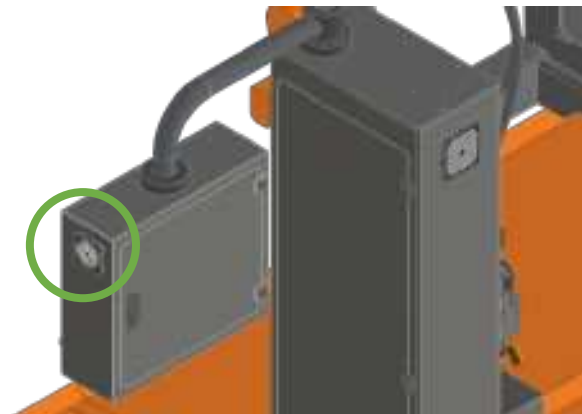

Fan carriage right

4 POSITIONERS MAINTENANCE

▽ Note: The secondary positioner (available on the twin version) is essentially the same as the main positioner, but with a smaller electronic panel, no welding power sources, and no gas cylinder holder, since power and gas is supplied by the main positioner.

The positioners controls the rotation of the pipes during the welding process.

Access panels to various internal components:

1 access panels on each side of the positioner, which provide access to the gear box, and rotative ground.

1 access panel on the rear of the positioner, which provides access to the electrical panel and servo drive.

2 access panels one on the front and one on the rear, which provide access to the fill welding power source (main positioner).

▽ Note: The main positioner contains the welding power sources

4.1 Rotative ground maintenance

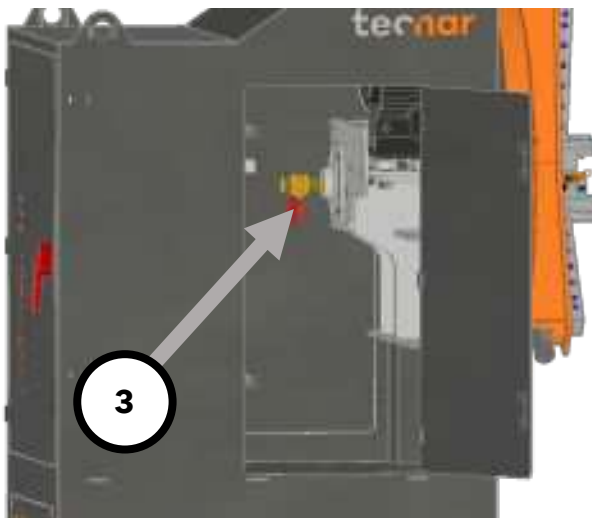

Side left panel (Main positioner)

ITEM	COMPONENT	DESCRIPTION
3	Rotative ground	Turns the positioner when a spool is being loaded or unloaded. It can only be used when the positioner is not controlled by the welding carriage pendant.

3.1	Rotative ground grease	Add grease accordingly (Tweco 8Z-L Shaft Lube)
-----	------------------------	------------------------------------------------

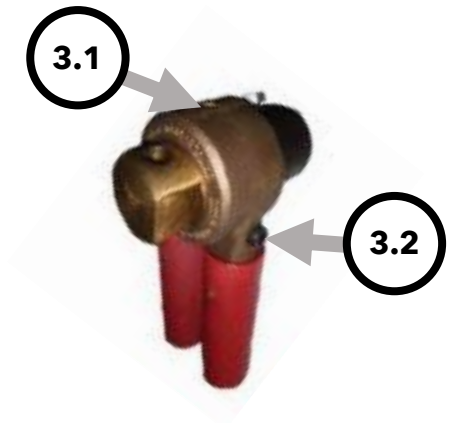

		
3.2	Rotative ground adjustment	Adjust, if needed, by turning the adjustment screw. Warning; if the rotary ground is too tight, the welding cables can wrap around the shaft and break cables.

4.2 Gas cylinder pressure regulator maintenance

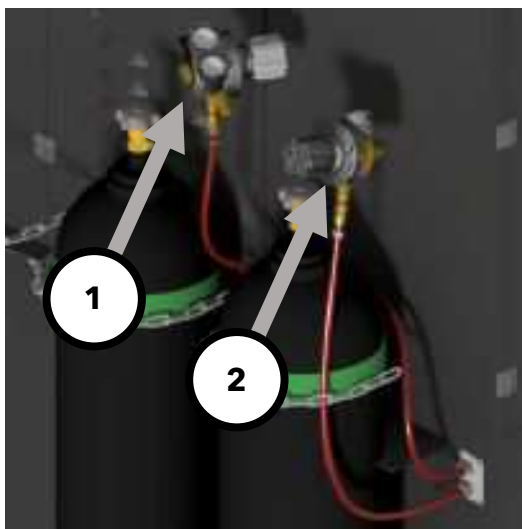

Gas cylinder pressure regulator

ITEM	COMPONENT	DESCRIPTION
1	Co2 gas pressure regulator (gray)	1. The pressure regulator should always be set at 30psi
2	Inert gas pressure regulator (black)	2. The pressure regulator should always be set at 30psi

4.3 Self centering chuck maintenance

1. Clean or replace chuck gripper accordingly

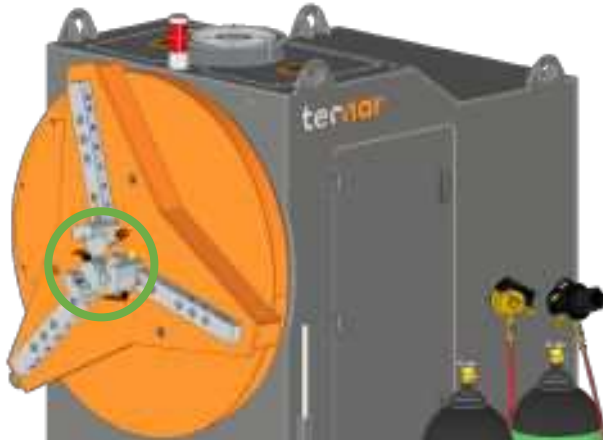

4.4 Gears assembly maintenance

To access the gear and pinion gear remove the front panel of the chuck



Pinion gear access panel

4.4.1 Gear lubrication

1. Verify if grease is needed, add accordingly.



Use Valvoline Crimson or equivalent multipurpose grease



VALVOLINE™ CRIMSON™ GREASE

Valvoline Crimson Grease is a preference among users with multiple grease applications, operating at moderate load carrying capacities, pressure, and temperature ranges. It is formulated with tackiness to heighten its ability to adhere to metal surfaces, and mobility for ease of pumping. This grease is fortified with an additive package that provides anti-wear protection, EP, rust and oxidation inhibition and copper corrosion resistance. Applications include: Trucking, industrial, Agriculture and Automotive.

Typical Properties:	ASTM Method	NLGI #2
Thickener		Lithium
Color	Visual	Red
KV@40 (cSt)	D445	150-220
Density		7.46 lb/gal
Operating Temp Range, °F		25-250
Timken, lbs	D2509	45
4-ball wear, scar diameter, mm	D2266	<0.6 max
4-Ball EP Load Wear Index @ XX kg	D2596	250
Load Wear Index	D2596	45
Rust Prevention	D1743	Pass
Dropping point, °F	D2265	380
Mobility @ 60°F	US Steel	350 min

Part Numbers:	NLGI #2
Bulk	VV70118
Tote	VV70117
400 Lb. Drum	VV70119
120 Lb. Keg (L)	VV70120
35 Lb. Plastic Pail	VV70122
50/14 Oz. Carton	VV70124

Refer to Valvoline's Safety Data Sheet for health and safety information.
This information only applies to products manufactured in the following location(s): USA, Canada.

4.4.2 Gear box maintenance

1. Visual inspection
 - Oil leak
 - Seal inspection

4.4.3 Gear backlash maintenance

1. Adjust backlash by loosen the screws of the gearbox and slide it to adjust it.
Don't exceed 1/64

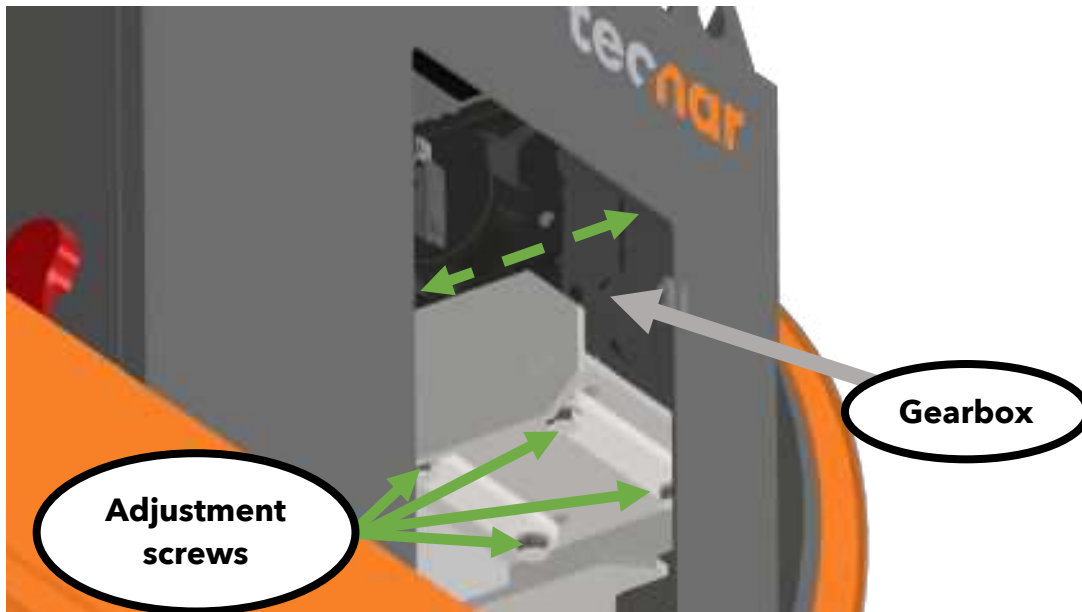

4.6 Pillow blocks maintenance

Use the side panel of the positioner to access the pillow block.

1. If needed, grease pillow block bearing with Valvoline Crimson or equivalent multipurpose grease.

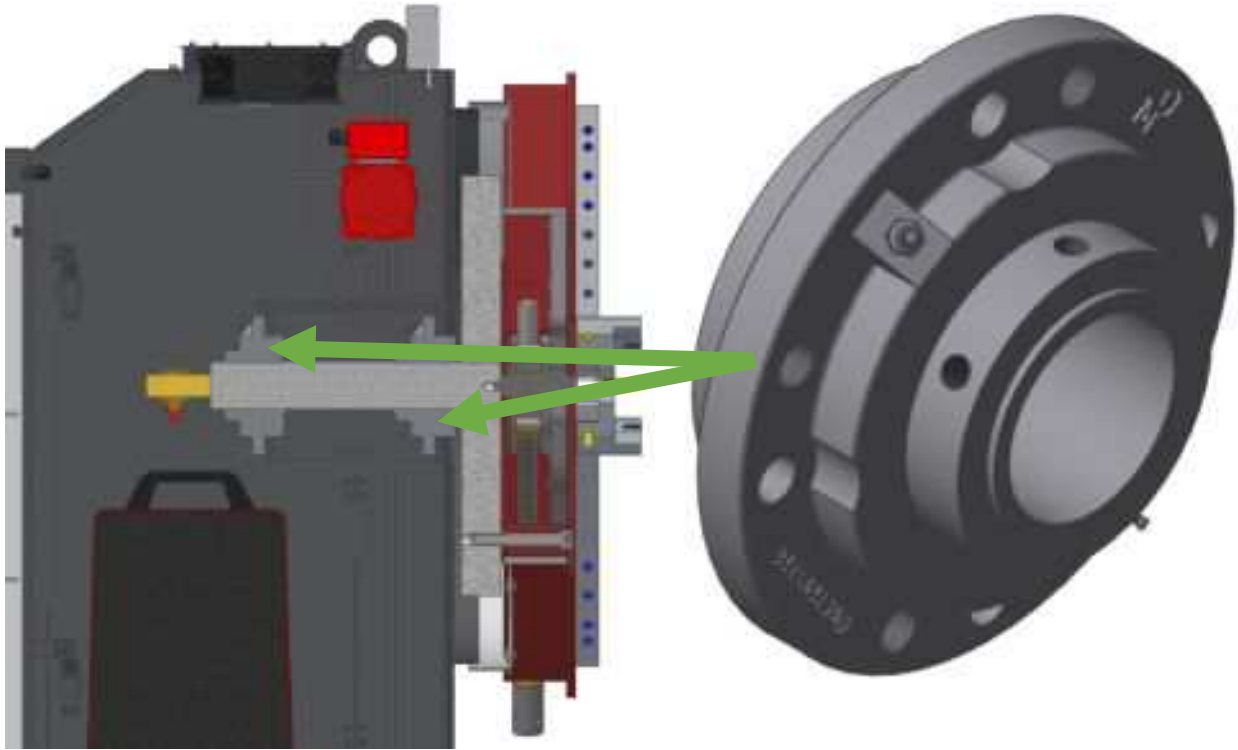

4.7 Root power source maintenance

4.7.1 STT II Preventive maintenance



A preventive maintenance should be done at least once every six months. It is good practice to keep a preventive maintenance record; a record tag attached to the machine works best.

1. Remove the machine wraparound cover and perform the input filter capacitor discharge procedure (detailed at the beginning of this chapter).
2. Clean the inside of the machine with a low pressure airstream. Be sure to clean the following components thoroughly.
 - Power Switch, Driver, Protection, and Control printed circuit boards
 - Power Switch
 - Main Transformer
 - Input Rectifier
 - Heat Sink Fins
 - Input Filter Capacitors
 - Output Terminals
 - Lower base compartment
3. Examine capacitors for leakage or oozing. Replace if needed.
4. Examine wraparound cover for dents or breakage. Repair as needed. Cover must be kept in good condition to assure high voltage parts are protected and correct spacings are maintained.
5. Check electrical ground continuity. Using an ohmmeter, measure resistance between either output stud and an unpainted surface of the machine case. Meter reading should be 500,000 ohms or more. If meter reading is less than 500,000 ohms, check for electrical components that are not properly insulated from the case. Correct insulation if needed.

4.7.2 STT II input filter capacitor discharge procedure

1. Turn off input power or disconnect input power lines.
2. Remove hex head screws from side and top of machine and remove wrap-around machine cover.
3. Be careful not to make contact with the capacitor terminals that are located in the center of the Switch Boards.
4. Obtain a high resistance and high wattage resistor (25-1000 ohms and 25 watts minimum).

This resistor is not supplied with machine. NEVER USE A SHORTING STRAP FOR THIS PROCEDURE.

Locate the two capacitor terminals (large hex head cap screws) shown in picture below.

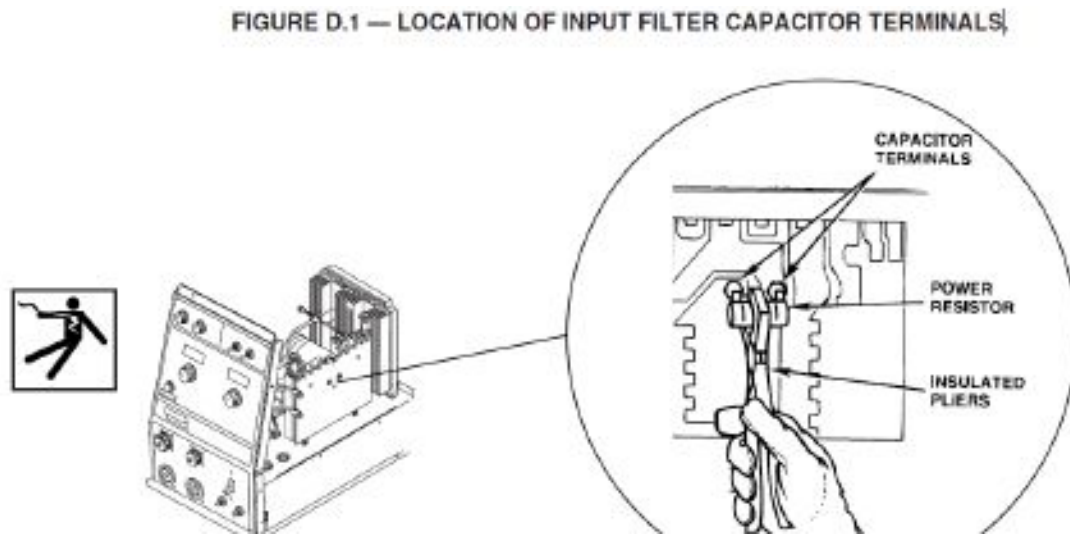

1. Use safety glasses, electrically insulated gloves and insulated pliers. Hold body of the resistor and connect resistor leads across the two capacitor terminals.
2. Hold resistor in place for 10 seconds.

DO NOT TOUCH CAPACITOR TERMINALS WITH YOUR BARE HANDS.

3. Repeat discharge procedure for capacitor on other side of machine.
4. Check voltage across terminals of all capacitors with a DC voltmeter. Polarity of capacitor terminals is marked on PC board above terminals. Voltage should be zero. If any voltage remains, repeat this capacitor discharge procedure.

4.7.3 STT module Power wave S500 Preventive maintenance



ROUTINE MAINTENANCE

Routine maintenance consists of periodically blowing out the machine, using a low-pressure air stream, to remove accumulated dust and dirt from the intake and outlet louvers, and the cooling channels in the machine. Also verify the STT® Module fan is operational when the power source fan is activated.

CALIBRATION SPECIFICATION

Due to the nature of its operation, calibration of the STT® Module is not required. From a system perspective, the output calibration of the power source and wire feeder should be performed as directed in their respective instruction manuals. When calibrating the power source voltage using the Weld Manager utility, the actual output voltage should be monitored directly at the output of the power source (not the STT® Module output). This is necessary because the default calibration mode senses voltage directly from the power source output studs. The STT® Module has no effect on the output current calibration.

4.8 Fill power source maintenance

CV400, Flextec 650 and Power wave S500 Fill power source maintenance



In extremely dusty locations, dirt may clog the air channels causing the welder to run hot with premature tripping of thermal protection.

1. Blow out the power source with low pressure air at regular intervals to eliminate excessive dirt and dust build-up on internal parts.

Calibration specification

Output Voltage and Current are calibrated at the factory. Generally, the machine calibration will not need adjustment. However, if the weld performance changes, or the yearly calibration check reveals a problem, use the calibration section of the Diagnostics Utility to make the appropriate adjustments.

The calibration procedure itself requires the use of a grid, and certified actual meters for voltage and current. The accuracy of the calibration will be directly affected by the accuracy of the measuring equipment you use. The Diagnostics Utility includes detailed instructions and is available at www.powerwavesoftware.com.

5 PIPE STANDS

Each positioner has two pipe stands, which can be moved along the tracks into the best positions for the spool

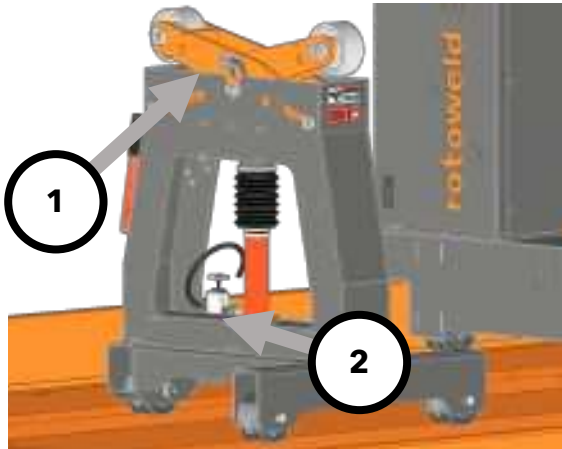

MIG model pipe support

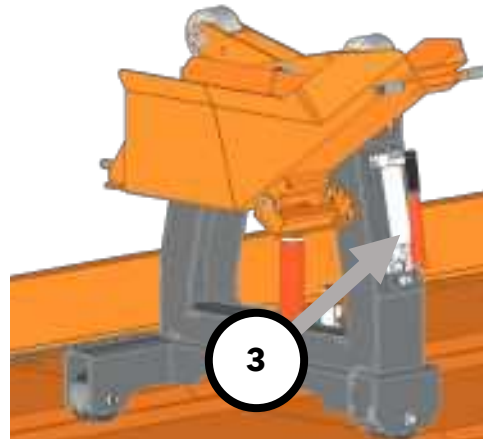

SAW model pipe support

ITEM	COMPONENT	DESCRIPTION
1	Hydraulic cylinder, hoses connections	Hydraulic cylinder to raise or lower the pipe support, connected with hoses.
2	Locking hydraulic valve	Locks the height of the rolls by closing the hydraulic circuit.
3	Manual pump	Feed oil to the hydraulic cylinder for extension.

Use the handles to tilt the flow basket to empty it

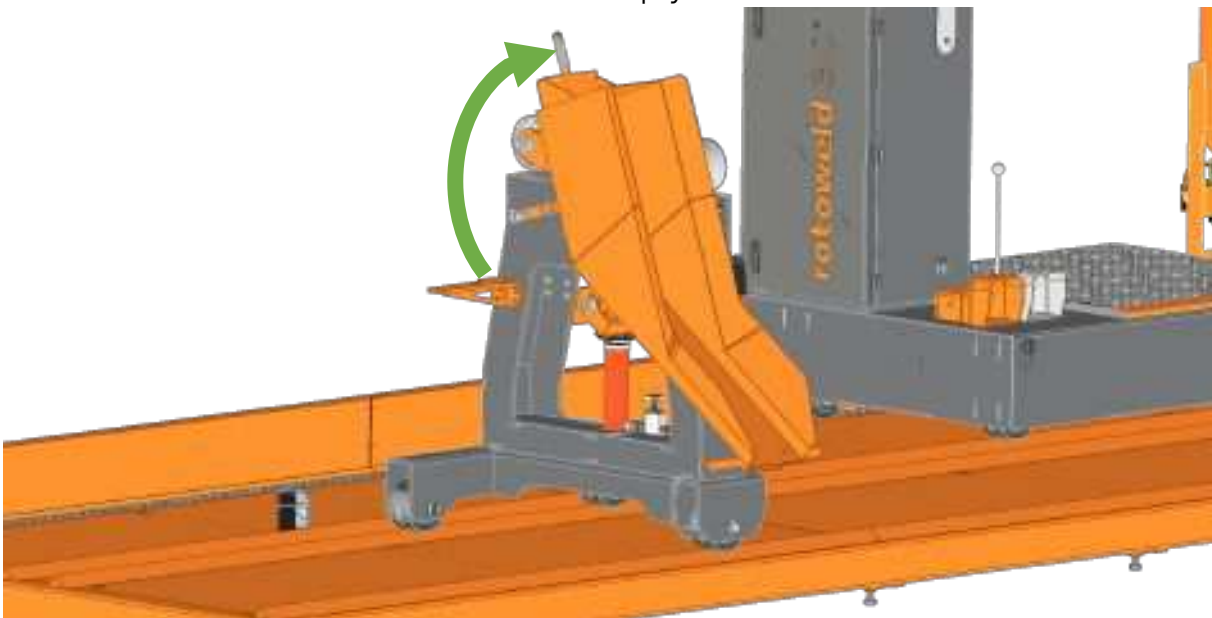

5.1 Hydraulic cylinder, hoses connection maintenance

1. Inspect for damages and fix if leaks are presents at connection points. Replace damaged hoses or components.
2. Inspect for damages and fix if leaks are presents at connection points.
3. Check oil level, try to raise the pipe stand to the maximum height until both wheels are touching. If you cannot reach this point, oil should be added to the pump reservoir. Lower the pipe stand to the lowest point, open the cap pump and refill. Use hydraulic oil SPX Power Team 9637 Hydraulic Standard Oil.

5.2 Locking hydraulic valve maintenance

Functionality test:

Make sure the manual pump have enough oil, refer to manual pump maintenance above.

1. With a heavy pipe on the pipe stand, close the locking valve (clockwise), open slowly the pump to release the oil to see if the pipe is going down. If it does a new locking valve maybe required.

5.3 Wheels maintenance

1. Grease wheels with Valvoline Crimson or equivalent multipurpose grease.

5.4 Flux pan maintenance

1. Transfer Flux from pans to pressure tank using proper screening for debris (if recycling of flux is permitted)

6 MAINTENANCE SCHEDULE RECOMMENDED

6.1 Daily

Cleaning:

Track, Carrier cable & cable tray.

Torch fill & root Nozzles

Transfer Flux from pans to pressure tank* using proper screening for debris (if recycling of flux is permitted)

Verification:

Welding Wire Spool remaining

Flux level pressurized tank*

Remaining pressure of the bottles of shielding gas

Replacement:

Fill Torch Contact Tip.

*Submerged Arc Welding Model

6.2 Weekly

Cleaning:

Jaw inserts on the chuck

Verification:

Inspection of the cable carrier, replace broken cap or links if required

Replacement:

N/a

6.3 Monthly

Cleaning:

Wire feeders rollers

Verification:

Torch nozzles (change if needed)

Test foot pedals on carriage and positioner(s) in each direction, inspect cable for damage

Chain tension for welding carriage

Water cooler level

Replacement:

Root Torch Contact Tip

Camera window

Fill torch liner

6.4 Quarterly

Cleaning:

Base of the welding carriage with a vacuum

Verification:

Visual inspection of the flow meters, flow meter for gas leak.

Water cooler level

Positioner Ground tightness and lubrication

Replacement:

Root torch liner

6.5 Annually

Cleaning:

Monitor

Inside of main and secondary positioners

Pump inlet strainer of the water cooler

Water cooler heat exchanger

Verification:

Inspection of the big and pinion gear on each positioner, add grease if needed (recommended grease: Valvoline Crimson™ Grease),

Chuck backlash

Gear box in each positioner (sign of wear and oil leak)

Welding ground attach to the end of the shaft of each turn table.

Leak from the water cooler

Welding torch

Flow meter for gas leak

Cable carrier, replace broken link if needed

Grease Pillow block and flange bearing of the positioner

Optical filter inside the optical tube of the camera

Pipe stand, hose, leak & oil level

Water cooler, re-oil the pump motor bearings

Replacement:

Coolant of the water cooler

